



Specifications

Insulator Material: Glass filled polyester, type PBT,
94 V-O, UL Rated.

Contact Material: Phosphor Bronze Alloy

Contact Plating: Gold and/or Tin over .000050" Nickel,
(See Contact Plating Options).

Current Rating: 5 amp at 30°C

Contact Resistance:
Contact to Daughter Card:
10 m Ω max.
Compliant section to P.T.H.:
2 m Ω max.

Insulation Resistance:
5000 M Ω min.

Dielectric Withstand Voltage:
1800 V AC

Daughter Board Insertion Force:
16 oz max. per contact pair
when tested with a .071" thick
gage.

Daughter Board Withdrawal Force:
1 oz min. per contact pair
when tested with a .054" thick
gage.

Compliant Section Insertion Force:
40 lbs max per contact

Compliant Section Withdrawal Force:
10 lbs min. per contact

Recommended Board Thickness:
.093"+

Operating Temperature:
-54°C to +125°C

Features

- Flat Plate Installation eliminates the need for secondary operation tooling which can damage the connector.
- Extra large chamfered entry
- Conforms to Bell-core spec TR-TSY-00078
- Extended card scoops available
- Replaceable contacts
- Molded in polarization available between contact, or on contact position.
- De-population of contacts per customer specification.
- Available in selective gold plate at contact point
- Many other custom options available, including, but not limited to:
 - Single or Both Ends Open
 - Shorting Contacts

For drawings, technical data or samples, contact E.C.S. at (714) 750-9410



Recognized under the recognized component Program of Underwriters Laboratories, Inc.
File Numbers: E176234

Recommended Hole Size

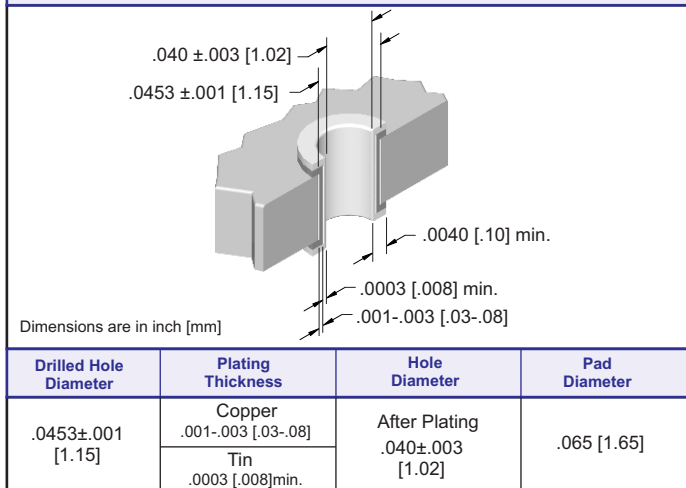

NO. OF POS./ CONTACTS	A	B	C
06/12	1.186 [30.12]	1.050 [26.67]	0.750 [19.05]
10/20	1.786 [45.36]	1.650 [41.91]	1.350 [46.29]
12/24	2.086 [52.98]	1.950 [49.53]	1.650 [41.91]
15/30	2.536 [64.41]	2.300 [58.42]	2.100 [53.34]
18/36	2.986 [75.84]	2.850 [72.39]	2.550 [64.77]
20/40	3.286 [83.41]	3.150 [80.01]	2.850 [72.39]
22/44	3.586 [91.08]	3.450 [86.63]	3.150 [80.01]
25/50	4.036 [102.51]	3.900 [99.06]	3.600 [91.44]
28/56	4.486 [113.94]	4.350 [110.49]	4.050 [102.87]
30/60	4.786 [121.56]	4.650 [118.11]	4.350 [110.49]
31/62	4.936 [125.37]	4.800 [121.92]	4.500 [114.30]
35/70	5.536 [140.61]	5.400 [137.16]	5.100 [129.54]
36/72	5.686 [144.42]	5.550 [140.97]	5.250 [133.35]
40/80	6.286 [159.66]	6.150 [156.21]	5.850 [148.59]
43/86	6.736 [171.09]	6.600 [167.64]	6.300 [160.02]

For reference only, can go 1 through 43 positions.

Dimensions are in inch [mm]

.150" x .200" Contact Spacing, Press Fit

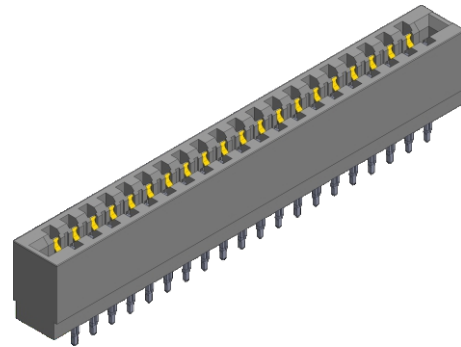
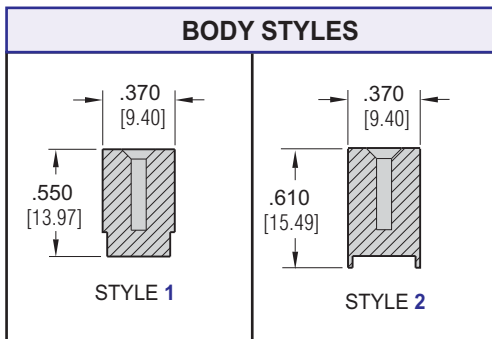
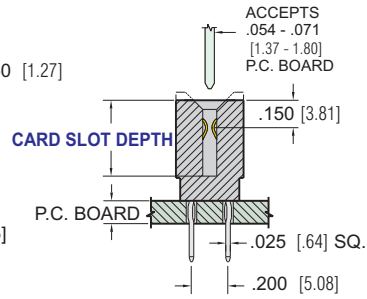
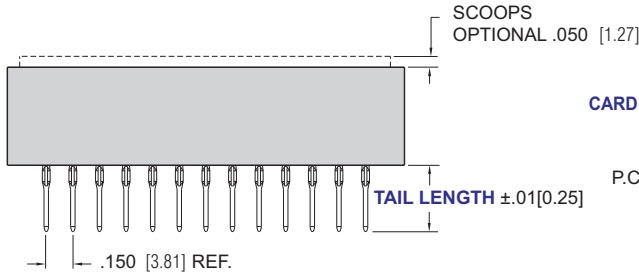
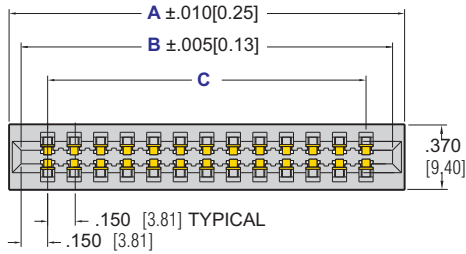

PART NUMBERING

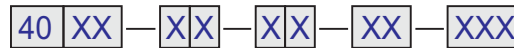

SERIES CODE
 .150" x .200" Contact Spacing

NO. CONTACT PAIRS
 01 - 43

SCOOPS
 S = With
 N = Without

BODY STYLES
 1 = .550 [13.97]
 2 = .610 [15.49]

CUSTOM VARIATION
 CONSULT FACTORY

TAIL LENGTH

BODY STYLE 1	BODY STYLE 2
1 = .190 [4.83]	1 = .190 [4.83]
2 = .375 [9.53]	2 = .315 [8.00]
3 = .465 [11.81]	3 = .405 [10.29]
4 = .625 [15.88]	4 = .565 [14.35]
5 = .710 [18.03]	5 = .650 [16.51]

CARD SLOT DEPTH

1 = .415 [10.54]
2 = .350 [8.89]
3 = .300 [7.62]

PLATING

50µ" Nickel Underplate	
CONTACT	TAIL
10 = 10µ" Au	100µ" Sn
20 = 15µ" Au	100µ" Sn
30 = 30µ" Au	100µ" Sn
40 = 10µ" Au	5µ" Au
50 = 15µ" Au	5µ" Au
60 = 30µ" Au	5µ" Au