

### Specifications

Insulator Material: Glass filled polyester, type PBT,  
94 V-O, UL Rated.

Contact Material: Phosphor Bronze Alloy

Contact Plating: Gold and/or Tin over .000050" Nickel,  
(See Contact Plating Options).

Current Rating: 3 amp at 30°C

Contact Resistance:  
Contact to Daughter Card:  
10 m Ω max.  
Compliant section to P.T.H.:  
2 m Ω max.

Insulation Resistance:  
5000 M Ω min.

Dielectric Withstand Voltage:  
1000 V AC

Daughter Board Insertion Force:  
16 oz max. per contact pair  
when tested with a .071" thick  
gage.

Daughter Board Withdrawal Force:  
1 oz min. per contact pair  
when tested with a .054" thick  
gage.

Compliant Section Insertion Force:  
40 lbs max per contact

Compliant Section Withdrawal Force:  
10 lbs min. per contact

Recommended Board Thickness:  
.093"+

Operating Temperature:  
-54°C to +125°C

### Features

- Flat Plate Installation eliminates the need for secondary operation tooling which can damage the connector.
- Extra large chamfered entry
- Conforms to Bell-core spec TR-TSY-00078
- Extended card scoops available
- Replaceable contacts
- Molded in polarization available between contact, or on contact position.
- De-population of contacts per customer specification.
- Available in selective gold plate at contact point
- Many other custom options available, including, but not limited to:
  - Single or Both Ends Open
  - Shorting Contacts

For drawings, technical data or samples, contact E.C.S. at (714) 750-9410



Recognized under the recognized component Program of Underwriters Laboratories, Inc.  
File Numbers: E176234

### Recommended Hole Size

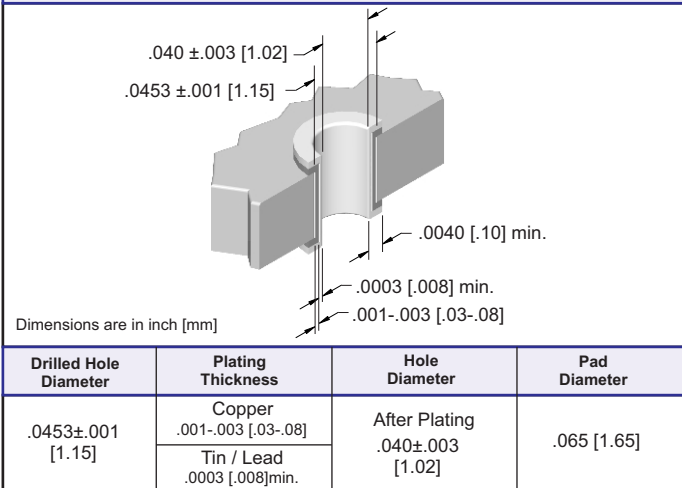

NO. OF POS. / CONTACTS	A	B	C
05/10	0.756 [19.20]	0.600 [15.24]	0.400 [10.16]
10/20	1.256 [31.90]	1.100 [27.94]	0.900 [22.86]
12/24	1.456 [36.98]	1.300 [33.02]	1.100 [27.94]
15/30	1.756 [44.60]	1.600 [40.64]	1.400 [35.56]
18/36	2.056 [52.22]	1.900 [48.26]	1.700 [43.18]
20/40	2.256 [57.30]	2.100 [53.34]	1.900 [48.26]
22/44	2.456 [62.38]	2.300 [58.42]	2.100 [53.34]
25/50	2.756 [70.00]	2.600 [66.04]	2.400 [60.96]
28/56	3.056 [76.62]	2.900 [73.66]	2.700 [68.58]
30/60	3.256 [82.70]	3.100 [78.74]	2.900 [73.66]
31/62	3.356 [85.24]	3.200 [81.28]	3.000 [76.20]
35/70	3.756 [95.40]	3.600 [91.44]	3.400 [86.36]
36/72	3.856 [97.94]	3.700 [93.98]	3.500 [88.90]
40/80	4.256 [108.10]	4.100 [104.14]	3.900 [99.06]
43/86	4.556 [115.72]	4.400 [111.76]	4.200 [106.68]
50/100	5.256 [133.50]	5.100 [129.54]	4.900 [124.46]
55/110	5.756 [146.20]	5.600 [142.24]	5.400 [137.16]
60/120	6.256 [158.90]	6.100 [154.94]	5.900 [149.86]
65/130	6.756 [171.60]	6.600 [167.64]	6.400 [162.56]
70/140	7.256 [184.30]	7.100 [180.34]	6.900 [175.26]

For reference only, can go 1 through 70 positions.

**.100"X.100" CONTACT SPACING**

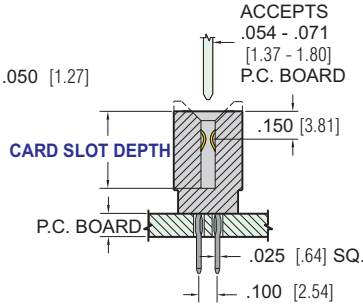
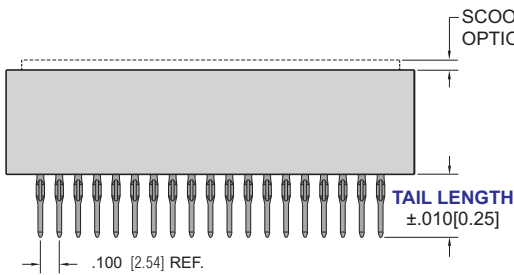
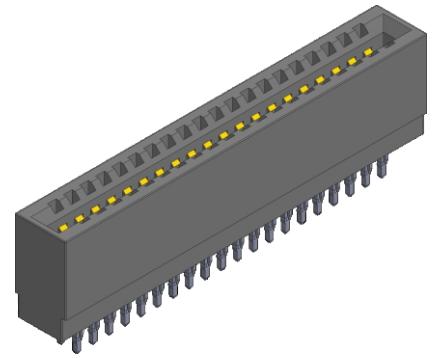
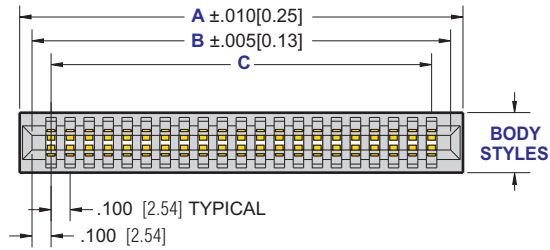

Dimensions are in inch [mm]

**BODY STYLES**

<p><b>STYLE 1</b></p>	<p><b>STYLE 2</b></p>	<p><b>STYLE 3</b></p>	<p><b>STYLE 4</b></p>
-----------------------	-----------------------	-----------------------	-----------------------

**PART NUMBERING**



**SERIES CODE**  
 .100" X .100" Contact Spacing

**NO. CONTACT PAIRS**  
 01 - 70

**SCOOPS**  
 S = With  
 N = Without

**BODY STYLES**

1 = .370 X .550 [9.40 X 13.97]
2 = .370 X .610 [9.40 X 15.49]
3 = .315 X .550 [8.00 X 13.97]
4 = .315 X .610 [8.00 X 15.49]

**CUSTOM VARIATION**  
 CONSULT FACTORY

**TAIL LENGTH**

<b>BODY STYLE 1,3</b>	<b>BODY STYLE 2,4</b>
1 = .190 [4.83]	1 = .190 [4.83]
2 = .375 [9.53]	2 = .315 [8.00]
3 = .465 [11.81]	3 = .405 [10.29]
4 = .625 [15.88]	4 = .565 [14.35]
5 = .710 [18.03]	5 = .650 [16.51]

**CARD SLOT DEPTH**

1 = .415 [10.54]
2 = .350 [8.89]
3 = .300 [7.62]

**PLATING**  
 50µ" Nickel Underplate

<b>CONTACT</b>	<b>TAIL</b>
10 = 10µ" Au	100µ" Sn
20 = 15µ" Au	100µ" Sn
30 = 30µ" Au	100µ" Sn
40 = 10µ" Au	5µ" Au
50 = 15µ" Au	5µ" Au
60 = 30µ" Au	5µ" Au

CONSULT FACTORY FOR CONNECTORS BUILT TO YOUR SPECIFICATION