

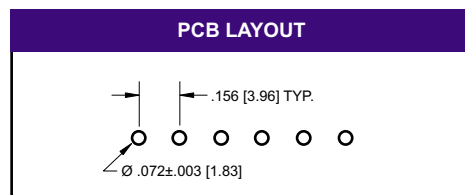

9000 Series .045 Square Power Terminals

Specifications

Insulator Material: Glass filled polyester, Thermoplastic,
 94V-O, UL Recognized.
 Contact Material: Copper Alloy
 Contact Plating: 100 μ " Tin over .000050" Ni.
 Insulation Resistance: 1000 M ohms at 500 VDC
 Dielectric Withstand Voltage: 1000 VAC/rms 60Hz for 1 min.
 Current Rating: 5 AMP
 Contact Resistance: 20 m ohms max. at 1 Amp DC
 Voltage Rating: 250 VAC/rms 80Hz
 UL File Numbers: E146967 & E176234

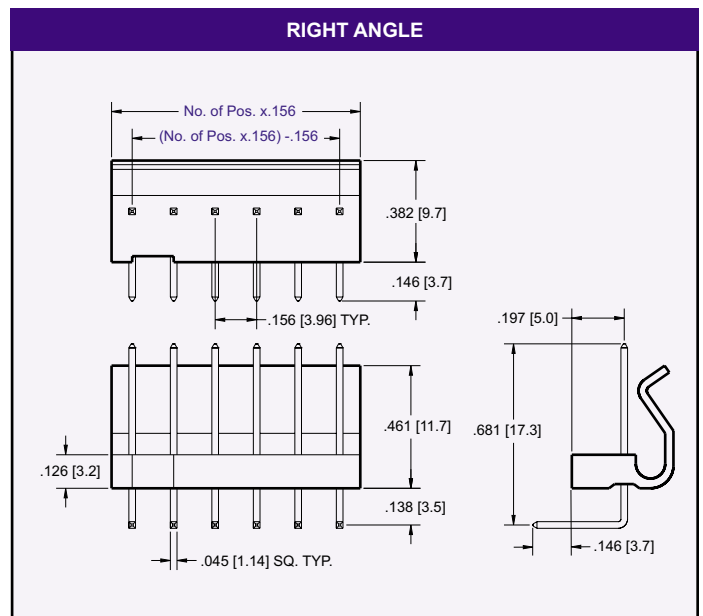
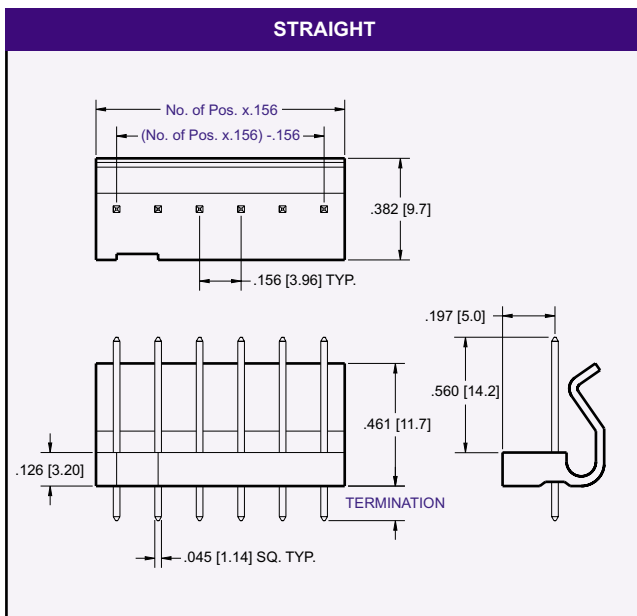
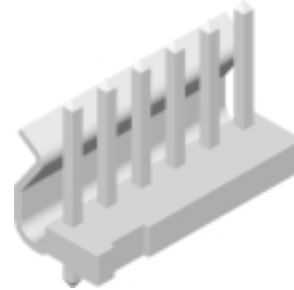

PART NUMBERING

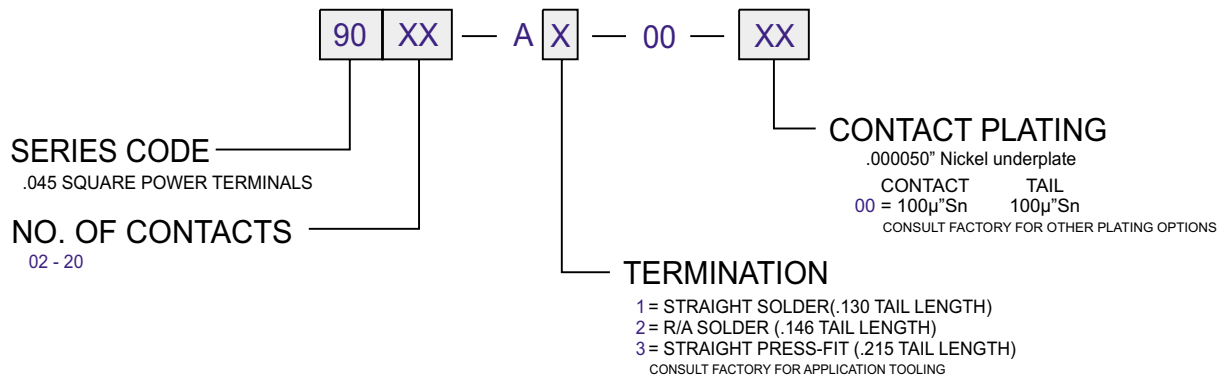

CONSULT FACTORY FOR CONNECTORS BUILT TO YOUR SPECIFICATION