



# 9800S Series Sockets

## .039 [1.00] SMT Box Socket

### Specifications

Insulator Material: LCP 94V-O UL Recognized.  
 Contact Material: Phosphor Bronze  
 Contact Plating: Gold over .000050" Ni  
 (See contact plating thicknesses).  
 Insulation Resistance: 5000 M ohms min.  
 Dielectric Withstand Voltage: 500 VAC  
 Current Rating: 1 AMP  
 Operating Temperature: -40°C To +105°C  
 Contact Resistance: 20 m ohms max.  
 Max. Processing Temp.: 230°C for 60 seconds  
 UL File Numbers: E146967 & E176234

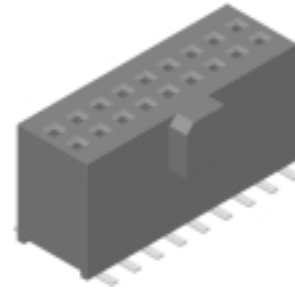

#### SUGGESTED MATING CONNECTOR

98XX-BX-XX-XX (PAGE F-02)

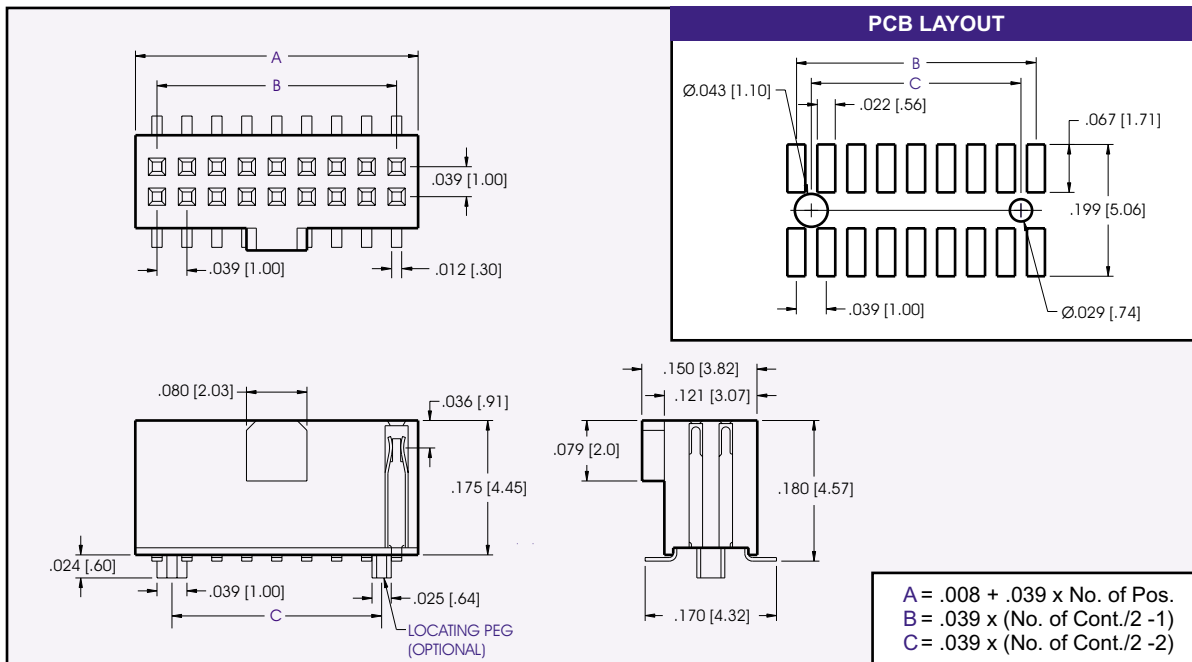

DIMENSIONS ARE IN INCHES & [MM]

### PART NUMBERING

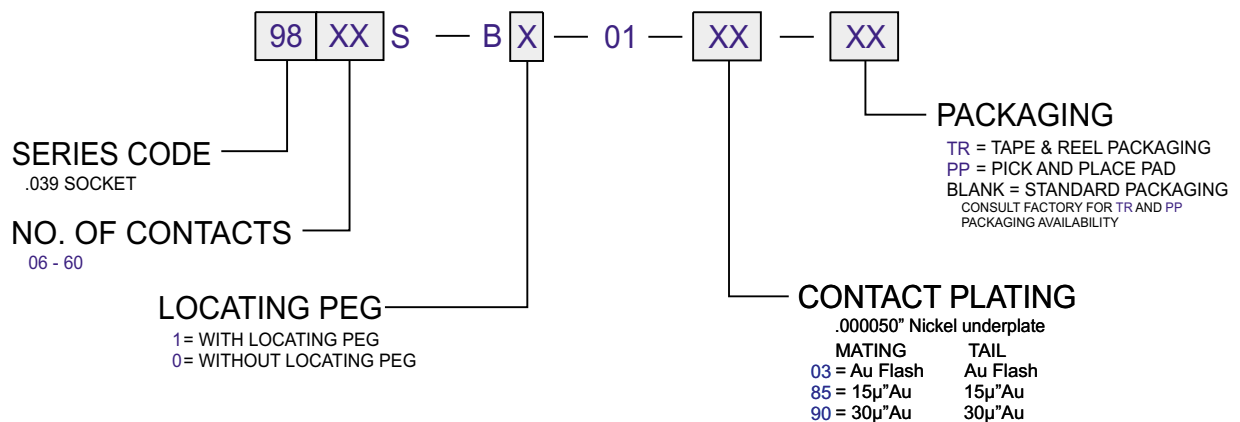

CONSULT FACTORY FOR CUSTOM CONNECTORS BUILT TO YOUR SPECIFICATION