



3100 Series Card Edge Connector

.156" X .200" Contact Spacing

Specifications

Insulator Material: Glass filled polyester, type PBT, 94 V-O, UL Rated.

Contact Material: Phosphor Bronze Alloy

Contact Plating: Gold and/or Tin over .000050" Nickel, (See Contact Plating Options).

Current Rating: 5 amp at 30°C

Contact Resistance:
Contact to Daughter Card:
10 m max.

Insulation Resistance:
5000 M min.

Dielectric Withstand Voltage:
1800 V AC

Daughter Board Insertion Force:
16 oz max. per contact pair
when tested with a .071" thick
gage.

Daughter Board Withdrawal Force:
1 oz min. per contact pair
when tested with a .054" thick
gage.

Operating Temperature:
-54°C to +125°C

Features

- Extra large chamfered entry
- Conforms to Bell-core spec TR-TSY-00078
- Extended card scoops available
- Replaceable contacts
- Molded in polarization available between contact, or on contact position.
- De-population of contacts per customer specification.
- Available in selective gold plate at contact point
- Many other custom options available, including, but not limited to:
 - Single or Both Ends Open
 - Shorting Contacts



Recognized under the recognized component Program of Underwriters Laboratories, Inc. File Numbers: E146967 and E176234

POS. / CONTACTS	A	B	C
06/12	1.228 [31.19]	1.092 [27.74]	0.780 [19.81]
10/20	1.852 [47.04]	1.716 [43.59]	1.404 [35.66]
12/24	2.164 [54.97]	2.028 [51.51]	1.716 [43.59]
15/30	2.632 [66.85]	2.496 [63.40]	2.184 [55.47]
18/36	3.100 [78.74]	2.964 [75.29]	2.652 [67.36]
20/40	3.412 [86.67]	3.276 [83.21]	2.964 [75.29]
22/44	3.724 [94.59]	3.588 [91.14]	3.276 [83.21]
25/50	4.192 [106.48]	4.056 [103.02]	3.744 [95.10]
28/56	4.660 [118.36]	4.524 [114.91]	4.212 [106.99]
30/60	4.972 [126.29]	4.836 [122.83]	4.524 [114.91]
31/62	5.128 [130.25]	4.992 [126.80]	4.680 [118.87]
35/70	5.752 [146.10]	5.616 [142.65]	5.304 [137.72]
36/72	5.908 [150.06]	5.772 [146.61]	5.460 [138.68]
40/80	6.532 [165.91]	6.396 [162.46]	6.084 [154.53]
43/86	7.000 [177.80]	6.864 [174.35]	6.552 [166.42]

For reference only, can go 1 through 43 positions.

Dimensions are in inch [mm]

MOUNTING STYLE

1 = Clearance Hole	2 = #4-40 Threaded Insert	3 = Flush Mount	4 = #4-40 Threaded Insert	5 = No Mounting Ear	6 = Side Mounting

.156" x .200" Contact Spacing

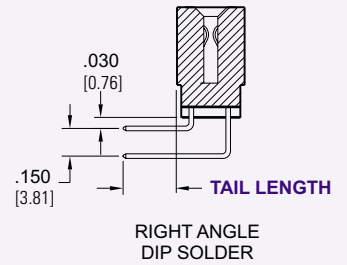
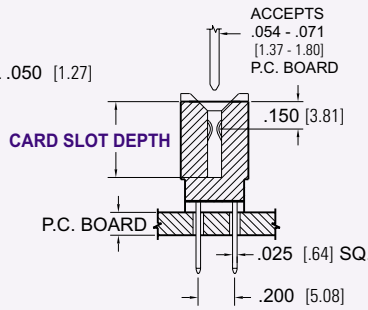
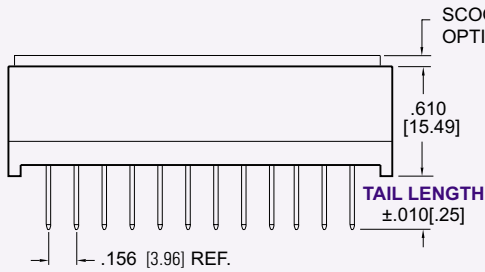
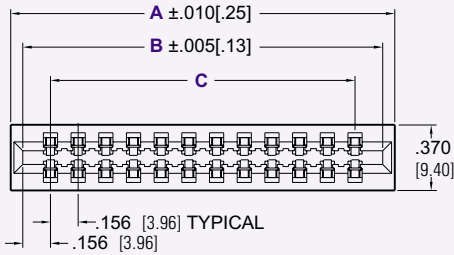
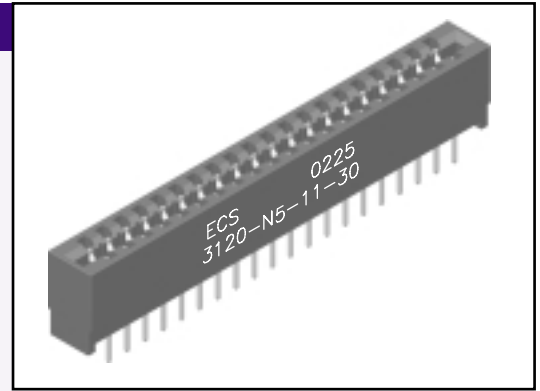

Dimensions are in inch [mm]

PART NUMBERING

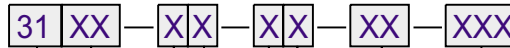

SERIES CODE
 .156 x .200 Centers Card Edge

NO. CONTACT PAIRS
 01 - 43

SCOOPS
 S = With
 N = Without

MOUNTING STYLE
 1 = Clearance Hole
 2 = #4-40 Threaded Insert
 3 = Flush Mount
 4 = Flush Mount / #4-40 Threaded Insert
 5 = No Mounting Ear
 6 = Side Mounting

CUSTOM VARIATION
 CONSULT FACTORY

TAIL LENGTH
 0 = .130 [3.30]
 1 = .190 [4.83]
 2 = .315 [8.00]
 4 = .565 [14.35]
 5 = .650 [16.51]
 6 = .100 [2.54] Right Angle
 7 = .180 [4.57] Right Angle
 8 = .250 [6.35] Right Angle

CARD SLOT DEPTH
 1 = .415 [10.54]
 2 = .350 [8.89]
 3 = .300 [7.62]

PLATING
 50µ" Nickel Underplate

CONTACT	TAIL
10 = 10µ" Au	100µ" Sn
20 = 15µ" Au	100µ" Sn
30 = 30µ" Au	100µ" Sn
40 = 10µ" Au	5µ" Au
50 = 15µ" Au	5µ" Au
60 = 30µ" Au	5µ" Au

CONSULT FACTORY FOR CONNECTORS BUILT TO YOUR SPECIFICATION