



60 Series Pinless Backplane Shroud Type Q, Q/2, Q/3

Specifications

Insulator Material: Glass filled polyester, type PBT,
94 V-O, UL Rated.
Insulation Resistance: 10^{12} m Ohms
Dielectric Strength: 500 VDC (Sea Level)
Temperature Rating: -55° C to 125° C



Recognized under the recognized component
Program of Underwriters Laboratories, Inc.

For drawings, technical data or samples,
contact E.C.S. at 714/895-6351

Features

- Interference Fit Mounting eliminates the need for additional Mounting Hardware.
- Shrouds are removable, facilitating field repairability.
- Eight sizes accommodate 3 wrap-post lengths used in a wide range of PCBs.
- Shroud retained on .61 - .64 [.024 - .025] square posts.

The pin less backplane shroud provides board-to board interconnections from the DIN type Q or B connector to a second DIN connector interface.

The shrouds accommodate a variety of extended contact lengths to provide a versatile, rear panel connection system.

PART NUMBERING

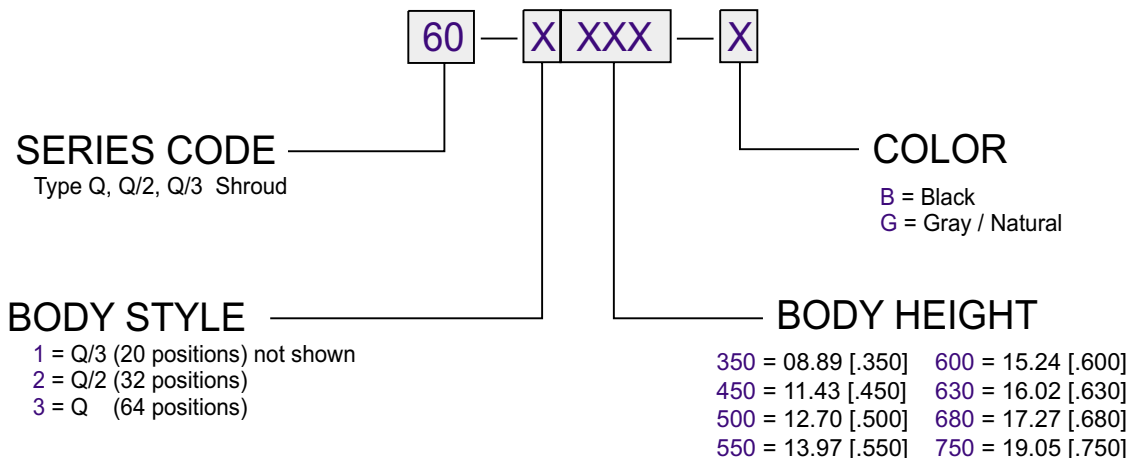

TYPE Q/2, 32 Positions

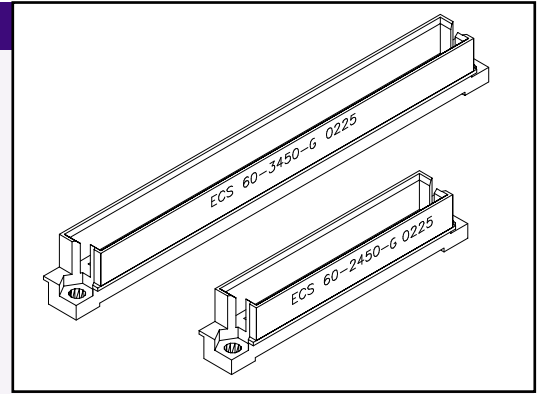
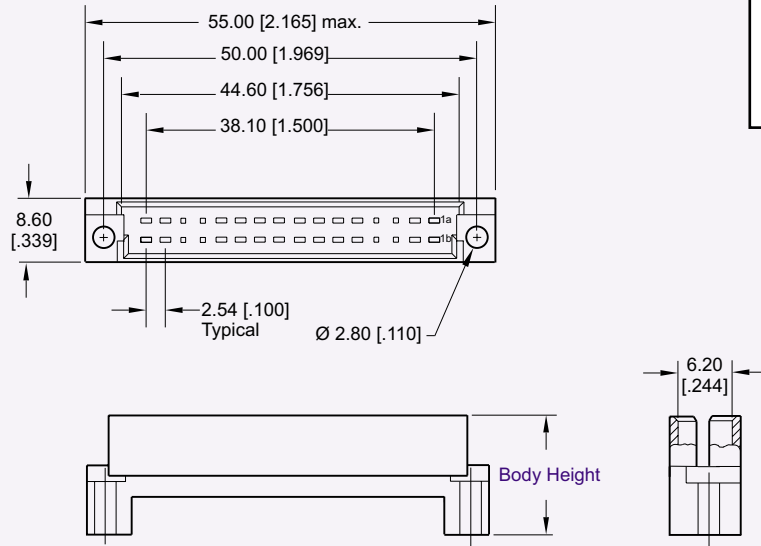

TYPE Q, 64 Positions

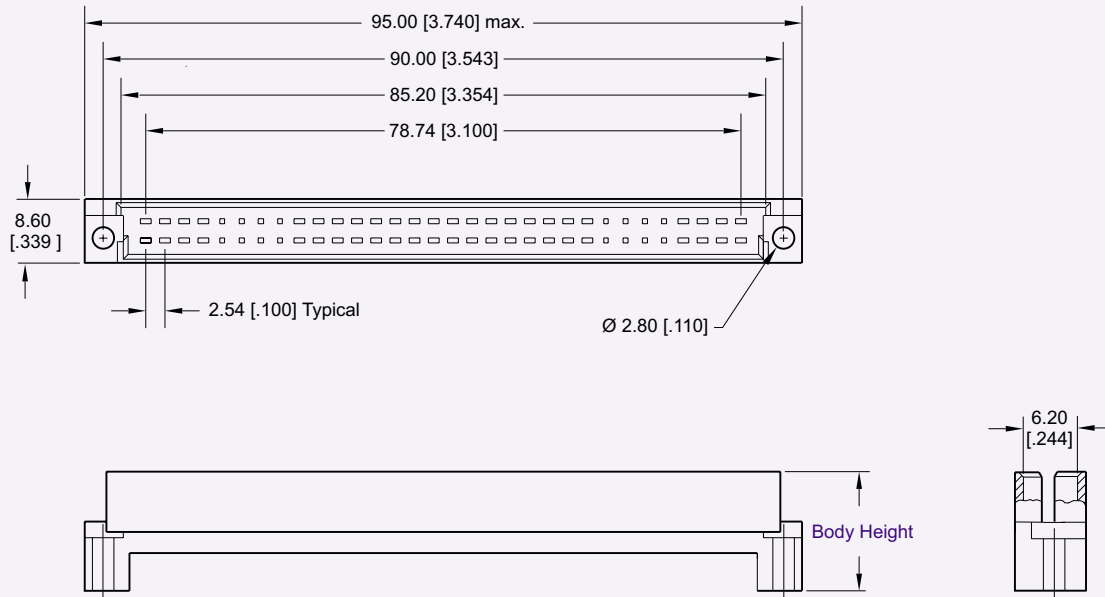

Dimensions are in mm [inches]

CONSULT FACTORY FOR CONNECTORS BUILT TO YOUR DESIGN