

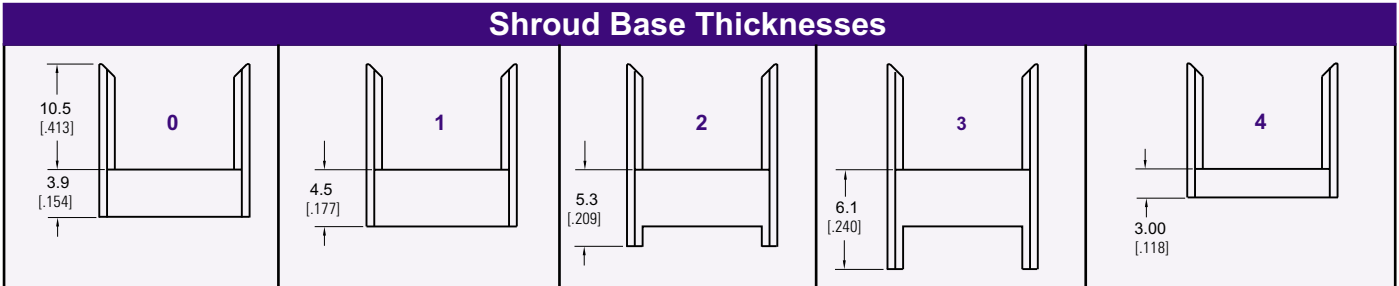

E-Z met™ 2mm HM

Type A, B, AB and C Shrouds

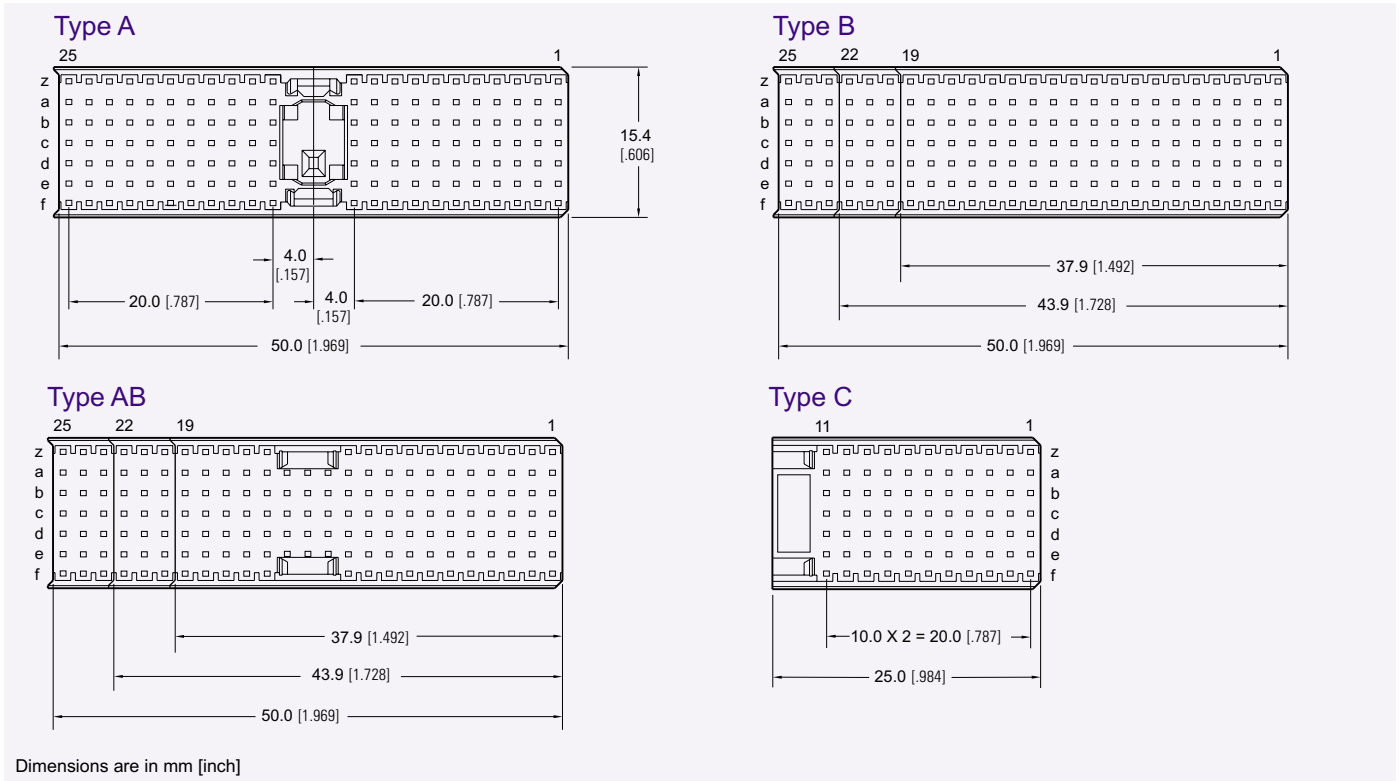

PART NUMBERING

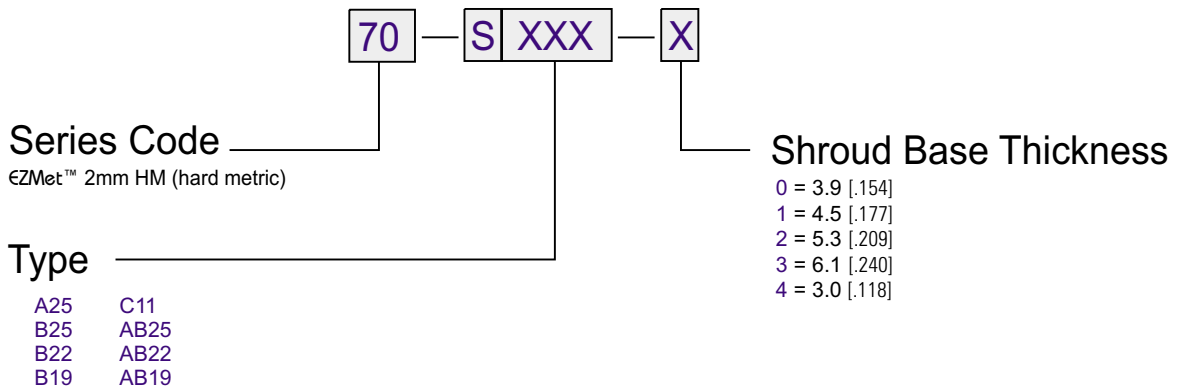

CONSULT FACTORY FOR ASSISTANCE TO ASSURE PROPER MATING